



"Seaways: Redefining Plastic Manufacturing with
Smart Auxiliary Solutions"

Vertical Batch Mixer Machine



Plot No.30 Sr No.662,663,664,
Surbhi Industrial Zone, Nr.Goldvitta Besan,
Village –Ravki, Rajkot–360004(Gujarat)

CALL NOW

+91 99 98 72 2228

www.seawaysmachinery.com



FRONT VIEW

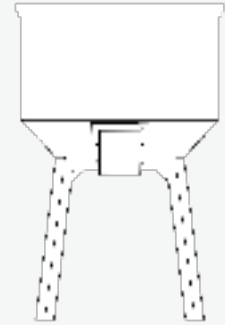

Stainless Steel Construction

Large discharge for material dispensing

Removable blade for easy clean out

Equipped with timer which can be set between 0-30 Minutes

Vertical Batch Mixer

Suitable Application :

- Suction Box
- Heating Element
- Auto Loading

Vertical Structure with castor wheel for high compatibility

Geared motor ensure low noise & High Torque

Short mixing period with low energy consumption and high productivity

SIDE VIEW

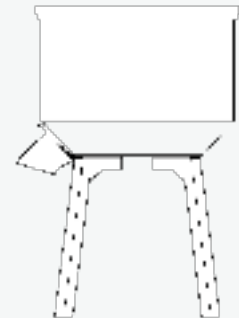

VERTICAL BATCH MIXER

MODEL	MOTOR KW/HP	CAPACITY (KG)	VOLTAGE	DIMENSION	R.SPEED (R/MIN.)	A.NET WEIGHT (KG)
SME-50	1.5/2	50	415 30	845*730*1020	85	125
SME-100	3/4	100	415 30	980*1000*1260	85	180
SME-150	4/5.5	150	415 30	1130*1010*1380	85	270
SME-200	7.5/10	200	415 30	1250*1170*1430	85	313

Seaways Machinery: A Trusted Name in Plastic Auxiliary
Equipment, Proudly Headquartered in Gujarat.

CALL NOW
+91 99 98 72 2228

www.seawaysmachinery.com

📍 Plot No.30 Sr No.662,663,664,
Surbhi Industrial Zone, Nr.Goldvitta Besan,
Village –Ravki, Rajkot-360004(Gujarat)



Vertical Batch Mixer Machine



Easy to mix big batch

Slow speed mixing ensures least powder generation

Easy loading bottom basket

Large material discharge

Stainless steel construction for long life & rust free operation

Equipped with inbuilt timer

Short mixing period

Front openable door for easy cleanout

Equipped with motor overload protection

All material contact point are non-ferrous

Compatible with hopper loader & conveyor

VERTICAL BATCH MIXER MACHINE

MODEL	POWER KW (HP)	CAPACITY (KG)	VOLTAGE	DIMENSION (MM)	ROTATING SPEED (RPM)	HEATING POWER (KW)	BLOWER (KW)	APPROX.NET WEIGHT (KG)
AVM-500	2.2 (3)	500	415V 3Φ	1170X1480X2425	300	12	0.34	450
AVM-1000	3(4)	1000	415V 3Φ	1385X1800X3026	300	18	1	630
AVM-2000	4(5)	2000	415V 3Φ	1680X2030X3650	300	30	1.5	1050
AVM-3000	5.5(7.5)	3000	415V 3Φ	2130X2130X3675	300	38	2.2	1250
AVM-5000	7.5 (10)	5000	415V 3Φ	3500X3500X3675	300	38	2.2	1500

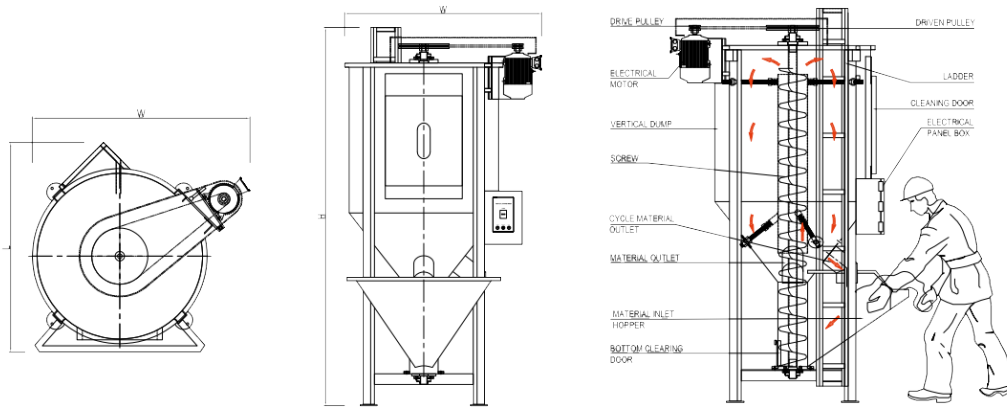

Seaways Machinery: A Trusted Name in Plastic Auxiliary Equipment, Proudly Headquartered in Gujarat.

CALL NOW
+91 99 98 72 2228

www.seawaysmachinery.com

📍 Plot No.30 Sr No.662,663,664,
Surbhi Industrial Zone, Nr.Goldvitta Besan,
Village –Ravki, Rajkot-360004(Gujarat)

