



"Seaways: Redefining Plastic Manufacturing with  
Smart Auxiliary Solutions"

## Plastic Crusher Machine ASG-F



Plot No.30 Sr No.662,663,664,  
Surbhi Industrial Zone, Nr.Goldvitta Besan,  
Village –Ravki, Rajkot–360004(Gujarat)

**CALL NOW**

**+91 99 98 72 2228**

[www.seawaysmachinery.com](http://www.seawaysmachinery.com)

# Plastic Crusher

## ASG-F

### **Suitable Application :**

- General purpose molded articles
- Runners, household articles
- Engineering plastics articles
- Thin pinch off



Flake cutter blades are suitable for recycling and restoring of conventional sheets, Tube plastics, profiles, packaging plastics, extrusion mold products and runners, etc.

ASG F series granulators are adopted with sealed bearings which can handle long hour operation. The unique design of the cutter ensures the uniform cutting.

Over load protection of motor

Rotary & Stationery blade for uniform grinding

Detachable screen & material bin for easy clean out

Openable cutting chamber

Easy to use with conveyor belt

Thermally treated blades for long life

Easy to grind material of minimum thickness 20 microns

MODEL	ASG-RF-3HP	ASG-RF-5HP	ASG-RF-7.5HP	ASG-RF-10HP
<b>Motor</b>	2.2 KW/3HP	4 KW/5HP	5.5 KW/7.5HP	7.5 KW/10HP
<b>Loading</b>	Ø 102	Ø 127	Ø 127	Ø 160
<b>Hopper</b>	100	100	200	200
<b>S.C.Model</b>	5-20	30-40	50	75-100

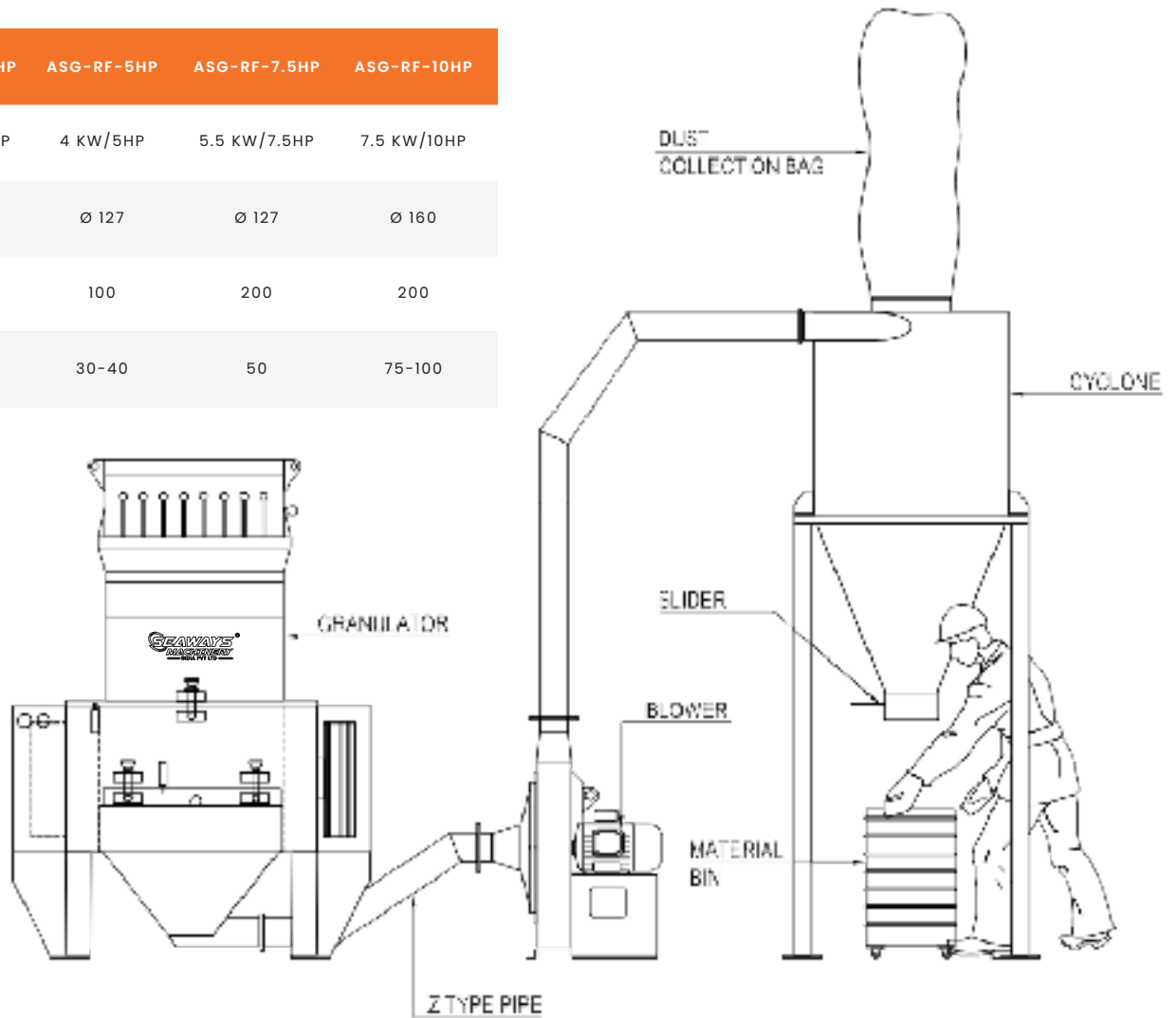

# PLASTIC CRUSHER

## ASG-F

MODEL	ASG-F-230	ASG-F-300	ASG-F-400	ASG-F-500	ASG-F-600	ASG-F-800	ASG-F-960	ASG-F-1100	ASG-F-1200
<b>Cutting Chamber(mm)</b>	230X200	310X200	410X240	510X300	610X330	815X470	960X610	1100X800	1200X800
<b>Cutting Capacity(KG/H)</b>	100-150	150-200	200-250	300-350	350-450	450-600	800-1000	1000-1200	1000-1500
<b>Stationary/ Rotary Cutter</b>	2/6	2/9	2/12	2/15	4/18	4/24	4/30	4/33	4/36
<b>Mesh Size (mm)</b>	8	8	8	10	10	10	12	12	12
<b>kw/HP</b>	4/5	5.5/7.5	7.5/10	11/15	15/20	22-30/ 30-40	37-45-57/ 50-60-75	75/100	75/100
<b>Dimensions (LXWXH) SP(mm)</b>	890X640X1145 1200X870X1510	1010X715X1300 1320X840X1950	1010X915X1350 1320X940X1840	1290X975X1670 1640X1080X1980	1290X1075X1740 1840X1180X2050	1735X1525X2180 1850X1540X2680	1950X1760X2740 2050X1850X2850	2510X2080X3700 2590X2230X3610	2510X2100X3700 2590X2230X3510
<b>Apporx.N.W. (kg) SP(kg)</b>	290 400	435 435	500 604	900 900	970 1180	2000 2380	3000 3500	6000 6500	6500 6800
<b>Maximum Cutting Thickness (mm)</b>	100-150	150-200	200-250	7	8	10	14	14	15
<b>Cooling</b>	YES	YES	YES	YES	YES	NO	NO	NO	NO

Seaways Machinery: A Trusted Name in Plastic Auxiliary Equipment, Proudly Headquartered in Gujarat.

**CALL NOW**  
**+91 99 98 72 2228**

[www.seawaysmachinery.com](http://www.seawaysmachinery.com)

Plot No.30 Sr No.662,663,664,  
Surbhi Industrial Zone, Nr.Goldvitta Besan,  
Village -Ravki, Rajkot-360004(Gujarat)

